

Newsletter!

No. 94

April 1994

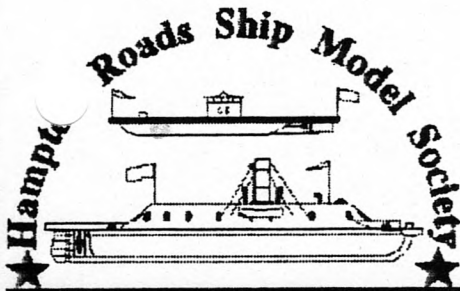
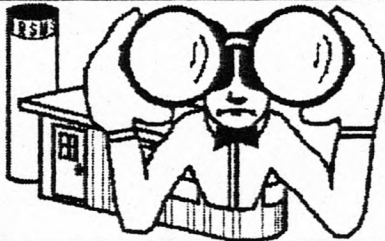

From the
Pilothouse



As I looked at our latest membership roster, I was impressed with the growth of the Hampton Roads Ship Model Society. I remember my first meeting some nine years ago. We had six members present. As our horizons, interests and enthusiasm have expanded, new members have joined. At this time I feel it appropriate that I convey our thanks to the most recent officers who gave freely of their time, namely Bill Altice, Len Wine and Alan Frazer. Bill Fox has ably filled the job of Historian and has agreed to continue in that capacity. I hope that we can continue our present course. I shall ring the bell but need to remind each of you that it is your club and your participation and input are critical to future success.

Jack

Bi-Society Meeting- Still waiting for a reply to our suggested fall meeting date.

New Business

New Members- Henry Schekulin and Ulrich Guenther both attended their third meeting. The new members were approved unanimously by the membership. (Jim McCurdy voted by proxy from the other room while getting another beer.)

Constitution and By-laws- The final signed copies of the new by-laws were passed out to all members who were present. Copies will be sent to all members who did not attend.

Mariner's Museum Park Day- David Tagg has received a letter from the Mariner's Museum announcing their Park Day, 24 April, and inviting the members to come and demonstrate RC models from 1200 to 1500 that day. The museum is not planning to erect any tents this year and they will be operating a 36' motor launch during the RC period, although the impact should be minimal. David recommended that Gene arm one of the torpedoes in his submarine and that would take care of the problem very quickly. It was recommended that we use the club canopy to set up a static display. The general consensus was that we would like to have a static display as well as the RC models.

Southside RC Club- The RC modelers on the southside are forming a

Minutes



The meeting was called to order at 2005.

Old Business

Annual Banquet- The annual banquet is on 26 March. Checks should be sent to Alan Frazer as soon as possible, \$18.00 per son. A cash bar will be provided.

Dues- Annual dues are due to the purser.

Aft- Behind or near the stern of a vessel.

Minutes Cont.-

Style guidelines are available for anyone interested in contributing.

Bill Altice also mentioned that HRSMS got its' name in the latest Broadaxe from New Jersey.

Newsletter- Len Wine announced that he is looking for any contributions for the newsletter, to include line drawings, how to tips, upcoming events, etc. Any and all contributions will be welcome.

The meeting adjourned at 2112 to refreshments provided by the Bergers. Also another opportunity to see Gene's masterpiece close-up.

could be a suitable substitute for many different types of gear systems. Nutating gears may have applications in modeling.

The basic concept is like this. Consider a coin that is spinning on a table. As it begins to slow down the coin wobbles. As it wobbles the coin traces a circle on the table. To understand this consider a point, A, on the edge of the coin. As the coin wobbles A comes in contact with the table at point B. A little while later as A again comes in contact with the table it will be a little farther around the circle at point C. See illustration. Try it with a quarter. As it wobbles you can see the head rotate. For every nutation (wobble) of the coin there is a partial rotation of the coin.

Upcoming Events

April						
S	M	T	W	T	F	S
					1	2
3	4	5	6	7	8	9
10	11	12	13	14	15	16
17	18	19	20	21	22	23
24	25	26	27	28	29	30

- 20 March- Annual Banquet
 - 8 April- Monthly meeting
 - 24 April- Mariner's Museum Park Day, Balao launching
 - 13 May- Monthly Meeting
 - Fall 1994- Bisociety meeting
 - October 1995- NRG Conference
- (Note- Please keep me informed of any upcoming events that may not show up in the newspaper.)



A nutating system is one in which one gear is nutating instead of rotating. See the illustration for a possible nutating gear system. I can make copies of the article for anyone who might be interested in seeing this in more detail.

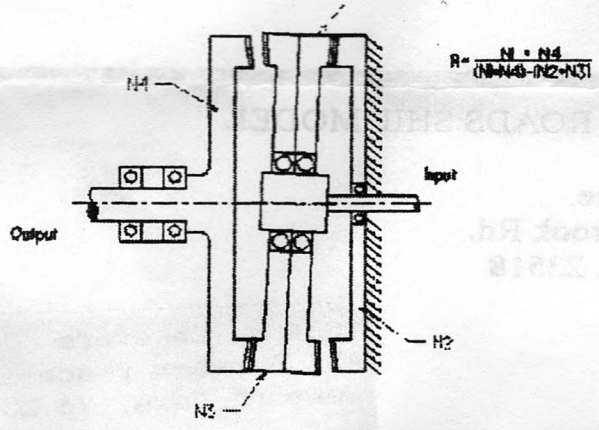

Notice to Mariners



Nutating Gears

The January 94 issue of Mechanical Engineering had an article about a system of gears, known as nutating gears, which

Channels or Chain-wales - Broad thick planks projecting horizontally from the side of a ship, used to spread the shrouds and thus provide better support for the masts. The upper ends of the chains pass through notches on the outer edge of the channels.

Next Meeting



Watch, Quarter and Station Bill



The next meeting will be on April 8 at 2000 at the home of John and Ellen Cheevers. Their phone number is 591-8955. The address is 414 Burnham Place, Newport News. Take Warwick Blvd to Glendale Road, 4 traffic lights north of the entrance to the Mariners Museum at J. Clyde Morris Blvd. Go one block east on Glendale to Burnham Place and turn right. John and Ellen are on the corner in a large house with a wraparound porch.

Skipper: Jack Bobbitt
599-0557
First Mate: Len Wine
588-5831
Clerk: John Cheevers
591-8955
Purser: Bill Clarke
868-6809
Historian: Bill Fox
253-0310
Editor: Len Wine

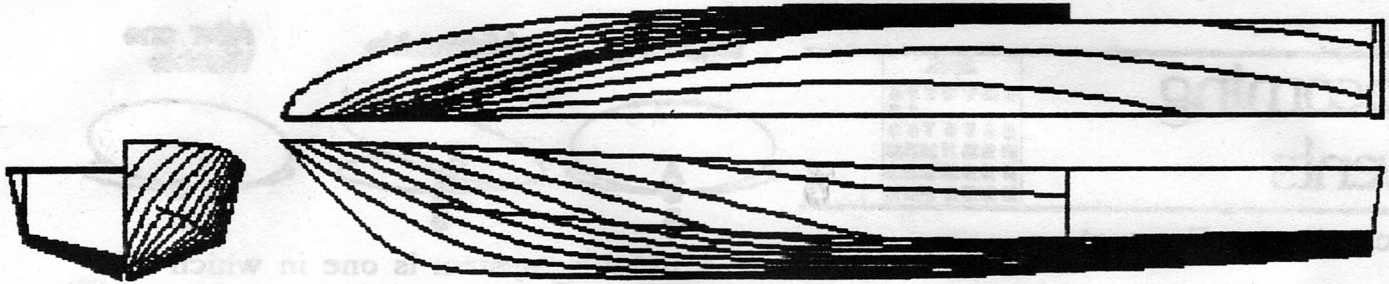

**USS Pegasus (PHM-1)
Lines Plan**

HAMPTON ROADS SHIP MODEL SOCIETY
c/o Len Wine
7432 Red Brook Rd.
Norfolk, VA 23518



John F. Cheevers
414 Burnham Place
Newport News, VA 23606

D

A: Dues paid. D: Dues due.

HRSMS Minutes, 11 March 1994

The meeting was called to order at 2005.

Attendance: 1) 15 Members.
2) 3 Guests: Tom Saunders (2d visit)
Henry Schekulin (3d visit)
Ulrich Guenther (3d visit)

Pursers Report: Alan Frazer reported a balance of \$1791.22 as of February 15.

Old Business

Annual Banquet- Bill Altice reminded the members that the annual banquet is on the 26th of March. Checks should be sent to Alan Frazer as soon as possible, \$18.00 per person. Jack Bobbitt announced that the country club had changed its position and would allow a cash bar.

Dues- Bill Altice also reminded the members that annual dues are due to the purser.

Bi-Society Meeting- Bill announced that he hadn't heard from the Washington group concerning our proposal to move the bi-society meeting to the fall. We're still waiting for their reply.

New Business

New Members- Bill Altice announced that Henry Schekulin and Ulrich Guenther were both attending their third meeting. Henry and Ulrich announced that they were interested in joining so all guests were asked to leave the room. The new members were approved unanimously by the membership. (Jim McCurdy voted by proxy from the other room while getting another beer.)

Constitution and By-laws- Alan Frazer passed out the final signed copies of the new by-laws to all members who were present. Copies will be sent to all members who did not attend.

Purser Transfer- Alan also pointed out that the club account needs to move to the new purser and asked for the clubs permission to go ahead and carry out the transfer. No dissension from the members. Bill Clarke mentioned that he was going to try and find a new bank, that would offer better incentives, for the club's account.

Mariner's Museum Park Day- David Tagg announced that he had received a letter from the Mariner's Museum announcing their Park Day and inviting the members to come and demonstrate RC models from 1200 to 1500 that day. The museum is not planning to erect any tents this year and they will be operating a 36' motor launch during the RC period, although the impact should be minimal. David recommended that Gene arm one of the torpedoes in his

submarine and that would take care of the problem very quickly. Alan Frazer mentioned that perhaps we could use the club canopy to set up a static display. The general consensus was that we would like to have a static display as well as the RC models.

Southside RC Club- Gene Berger announced that the RC modelers on the southside are forming a club. Details to follow.

NRG Contribution- Jack Bobbitt recommended making a larger donation to the NRG than just the standard membership fee. Both Bill Altice and Alan Frazer agreed that it would be appropriate. Bill Hinrichs moved to make a \$60.00 donation to the Nautical Research Guild which would be a sustaining membership. Len Wine seconded the motion. The motion passed unanimously.

Lifesaving Museum- Gene Berger received a letter from Ann Dearman at the Lifesaving Museum thanking us for our participation in the modeling exhibit on February 19th and inviting us back next year. Gene thought we probably saw 20 to 30 people during the afternoon.

NRG Club Roster- Bill Altice reminded Jack that he needs to update the address in the NRG club roster to reflect our new skipper. Jack said he would get in touch with them. The decision was also made to have John Cheevers continue to receive the club copy of the NRG Journal.

1994 NRG Conference- Alan Frazer passed around a letter from Jeff Phillips published in the latest issue of Model Ship Builder (MSB) describing the 1994 NRG Conference to be held in Manitowoc, Wisconsin, September 23-25. See MSB for details.

Seaways, Ships in Scale- Alan also had a letter from Jim Raines of Seaways. Jim is looking for articles. He will provide submission guidelines upon request. The decision was made, without dissent, to provide Jim a copy of the club roster so everyone can get a copy of the guidelines.

Woodcarvers Catalog- The next topic of conversation was the recollection that John Cheevers was going to provide the club roster to the Woodcarver guy in Virginia Beach so we could all receive catalogs. Only a few of the members have received the catalog. There was general speculation on how much money John made selling the list. (Particularly since John wasn't there to defend himself).

Old-New Business

1995 NRG Conference- It was decided to make the upcoming conference an agenda item at all future meetings. Bill Clarke mentioned the possibility of getting Simon Stevens (sp?), a curator at the National Maritime Museum in Greenwich, England, to be a speaker at the conference. That raises the question of how many speakers to have, 5 or 6. Bill is also pushing for an extra

day for the vendors and a fleamarket on Sunday. Also the idea was raised of going to Nauticus as part of the boat tour on Friday. AS Bill said, "Get braced. It's coming."

Announcements

IMAX Film Titanica- Alan Frazer announced that beginning April 24 or 25 and running through November the Hampton Roads Air and Space Museum will be running the IMAX film Titanica. Mariners Museum members can receive a discount on admission. The film is about the Titanic and includes some underwater footage.

Model Sold- Graham Horne mentioned that the latest issue of Wooden Boats had a brief article describing a 3" model by McCaffery that recently sold for \$100,000. Henry Schekulin felt that the model wasn't really worth that much, having had an opportunity to see it. Certainly it was a very difficult model but certain aspects were not great, particularly the rigging.

Mid-Atlantic Maritime Festival- Graham also announced that this years Maritime Festival will be held the weekend of 22-24 April and the Washington society will be heavily involved again. The festival will be held in Easton, Maryland. Bill Altice and Hugh Melton both said they had a good time last year.

Scale Conversion Chart- Hugh Has used Lotus to create a scale conversion chart. He can do it for any scale to a large number of decimal places. Anyone interested can contact Hugh. Bill Altice mentioned that he sells vernier calipers. Graham Horne mentioned that he is looking for a scale that divides 1" into 12 equal parts. Can anyone help. The general consensus is that an architects rule does that but no one is sure.

Washington Ship Model Society Newsletter- The latest Washington newsletter included 2 things from the NRG.
1. The NRG is looking for people to do book reviews.
2. Style guidelines are available for anyone interested in contributing.

Bill Altice also mentioned that HRSMS got its' name in the latest Broadaxe from New Jersey.

Newsletter- Len Wine announced that he is looking for any contributions for the newsletter, to include line drawings, how to tips, upcoming events, etc. Any and all contributions will be welcome.

The meeting adjourned at 2112 to refreshments provided by the Bergers. Also another opportunity to see Gene's masterpiece close-up.